

THIS DRAWING IS UNPUBLISHED. RELEASED FOR PUBLICATION, 19 .
 © COPYRIGHT 19 BY AMP INCORPORATED, HARRISBURG, PA. ALL INTERNATIONAL RIGHTS RESERVED. AMP PRODUCTS MAY BE COVERED BY U.S. AND FOREIGN PATENTS AND/OR PATENTS PENDING.

LOC		DIST		P		F		ZONE		LTR		REVISIONS		
CE	00											DATE	APPROVED	
										M		ECR-05-011147	130C705	KG/DK

- DIMENSIONS IN [] ARE IN INCHES
- CONNECTOR WITHOUT KEY IS TYPE S
- HOUSINGS: PBT MOLDING COMPOUND
 NUT: PBT MOLDING COMPOUND
 FERRULE ASSY: STAINLESS STEEL AND CERAMIC
 INNER CRIMP RING: BRASS
 OUTER CRIMP RING: COPPER
 STRAIN RELIEF: POLYPROPYLENE
 DUST COVER: THERMOPLASTIC RUBBER
- INSTRUCTION SHEET 9373
- BULK PACKAGED, 200 PER PACKAGE.

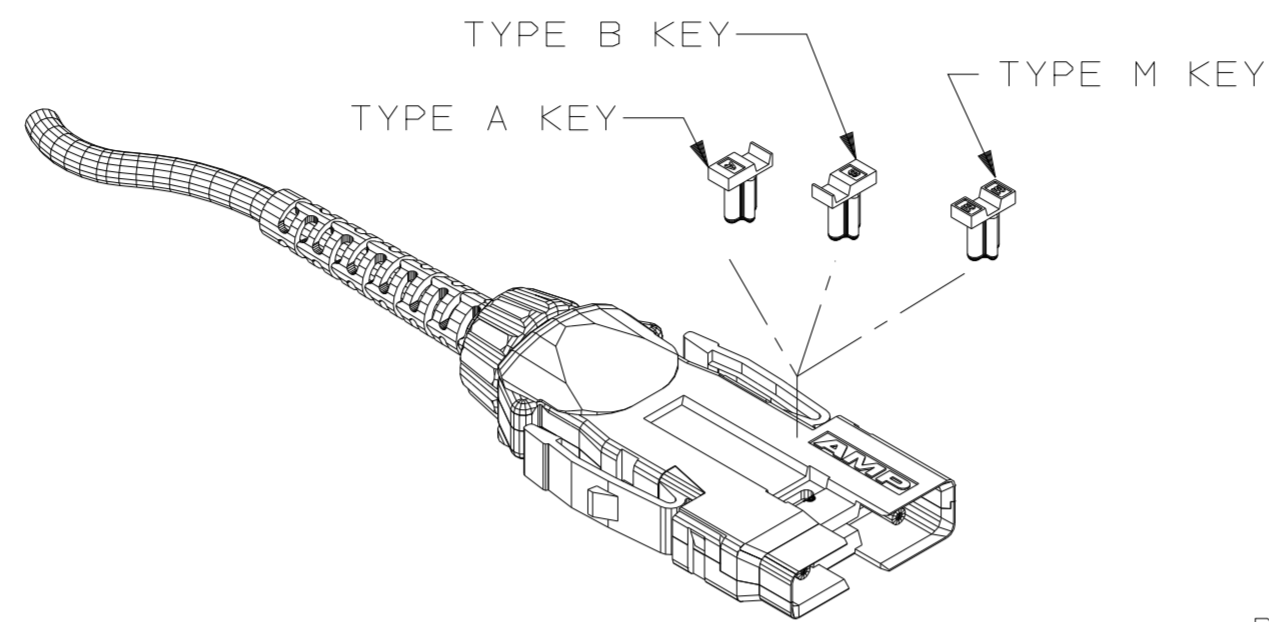

DUST COVER NOT SHOWN

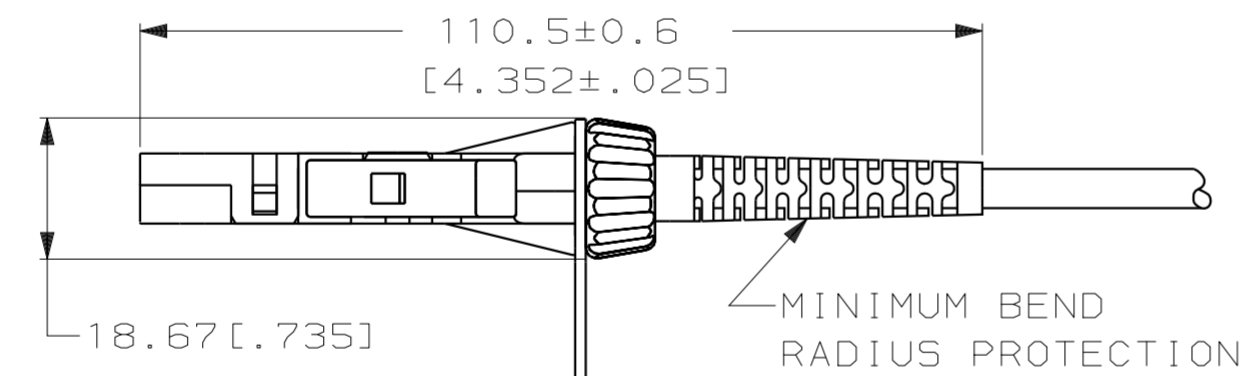
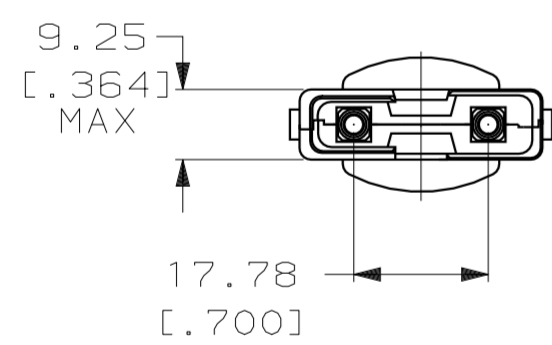
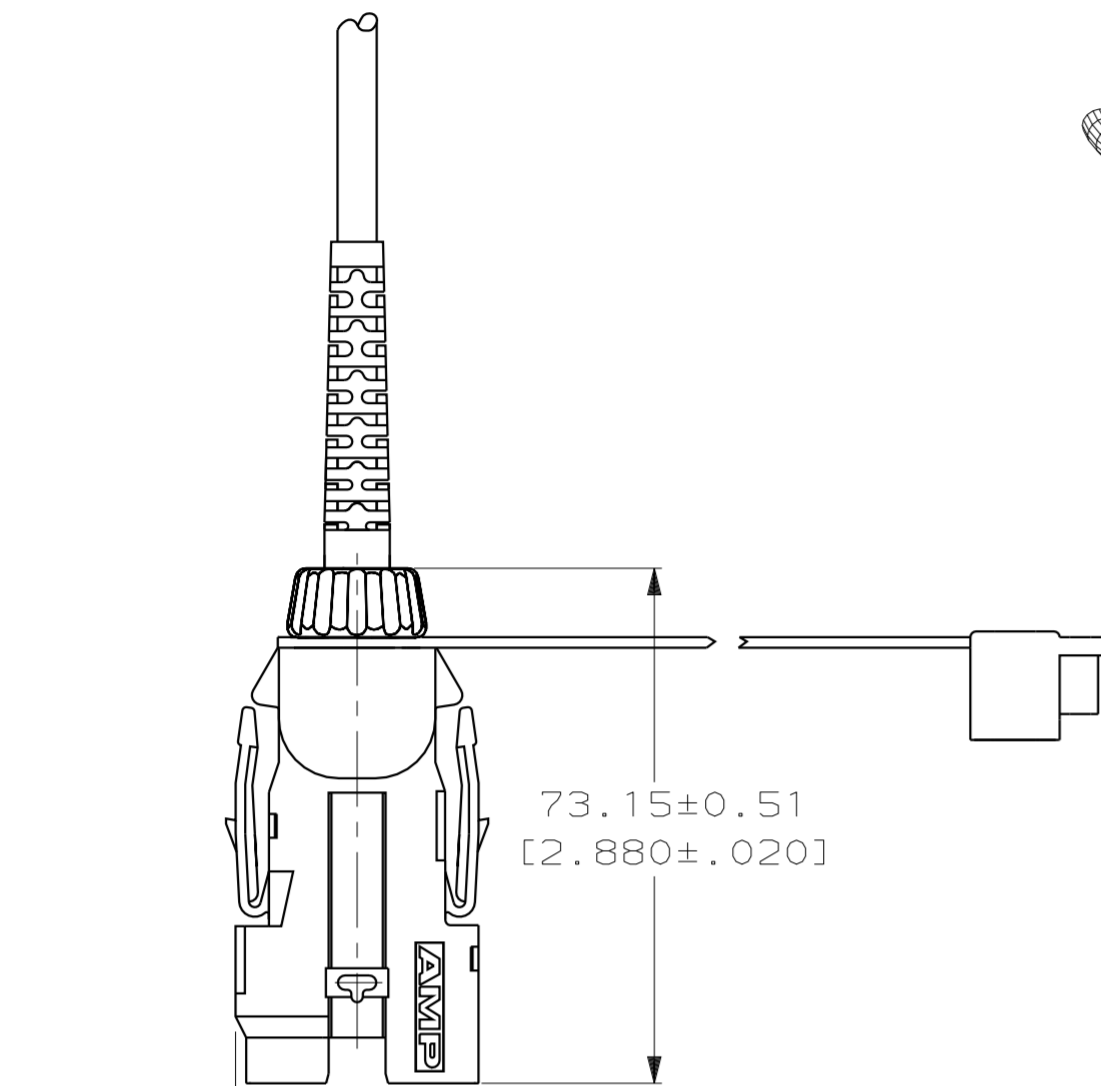
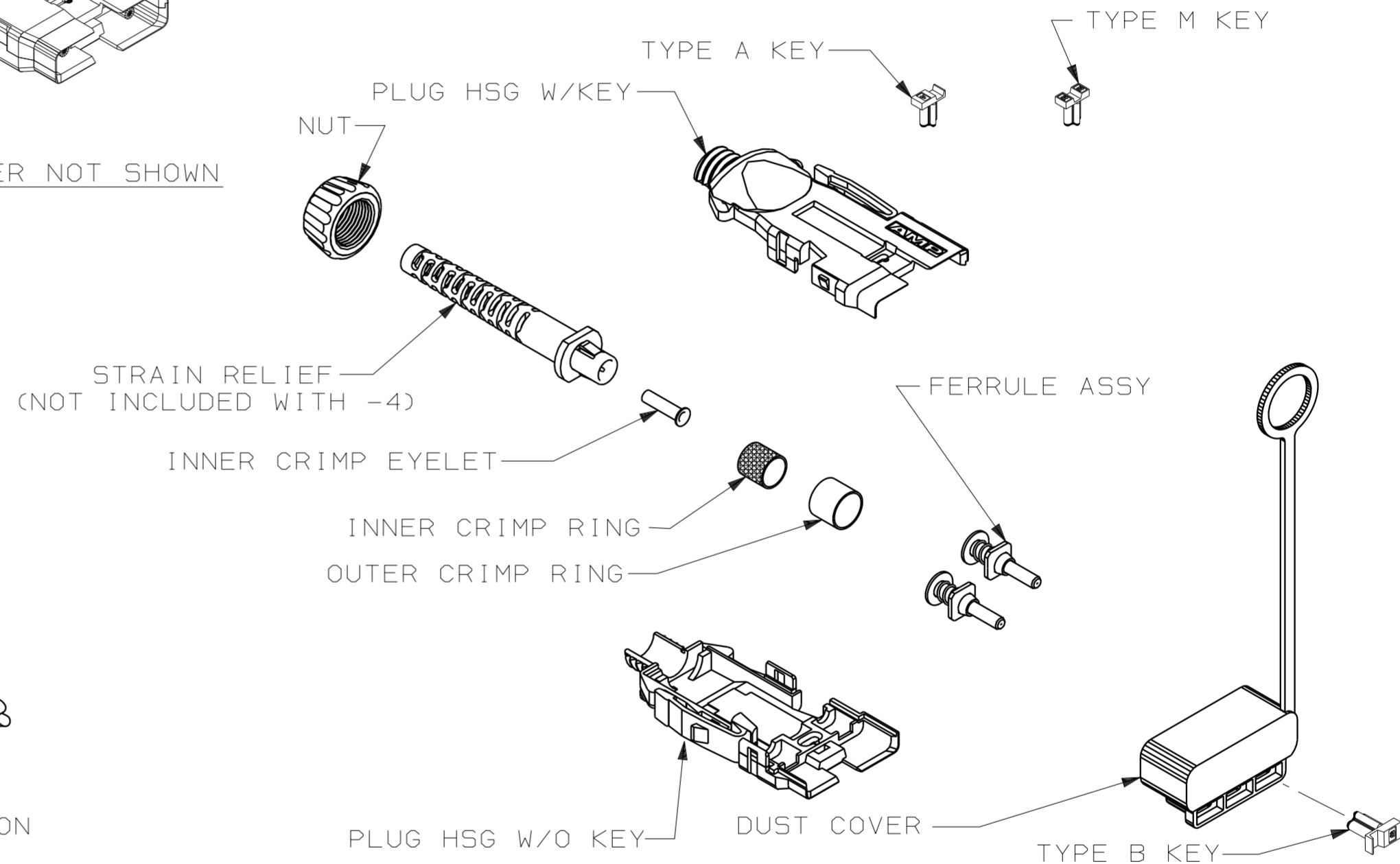

6 BULK PACKAGED 50 PER PACKAGE. ORDER STRAIN RELIEF SEPARATELY. DUALAN STYLE: 501783-1 ZIPCORD STYLE: 502016-1

FIBER SIZE	PART NO
125µm	501780-4
125µm	501780-3
140µm	501780-2
125µm	501780-1

UNLESS OTHERWISE SPECIFIED DIMENSIONS ARE IN mm TOLERANCES ON :		DR 5-19-88 B.BRIGGS		AMP INCORPORATED Harrisburg, Pa. 17105	
2 PL DEC ±0.13 [.005]		CHK 5-19-88 J.ZEIDERS			
3 PL DEC ± -		APPD 5-20-88 L.BUDD		NAME CONNECTOR KIT, DUALAN CABLE, AMP FSD	
ANGLES ± -		APPD 5-20-88 D.THOMPSON			
MATERIAL		PRODUCT SPEC		SIZE	
3		-		C	
FINISH		APPLICATION SPEC		FSCM NO	
-		-		00779	
WEIGHT		-		DRAWING NO	
-		-		501780	
		SCALE 1:1		SHEET 1 OF 1	

METRIC

RESTRICTED RELEASE
 DRAWING MAY CHANGE WITHOUT
 CUSTOMER NOTIFICATION